

6. Select connecting rod big end inserts using the following chart and the markings on the crankshaft and connecting rod.

Big End Bearing Insert Selection		
Con-Rod Big End Bore Diameter Marking	Crank Pin Diameter Mark	Bearing Insert
		Size Color
None	○	Brown
None	None	Yellow
○	○	Green
A	None	

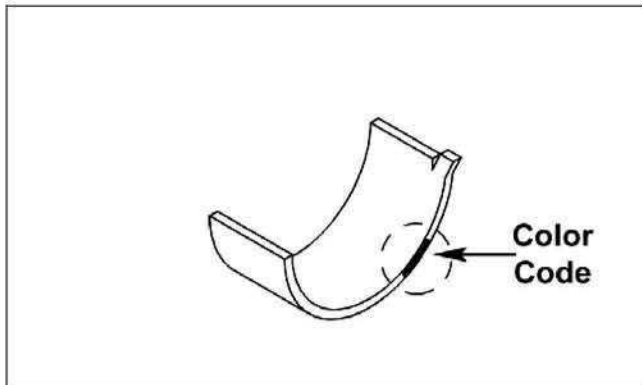

ATV2082A

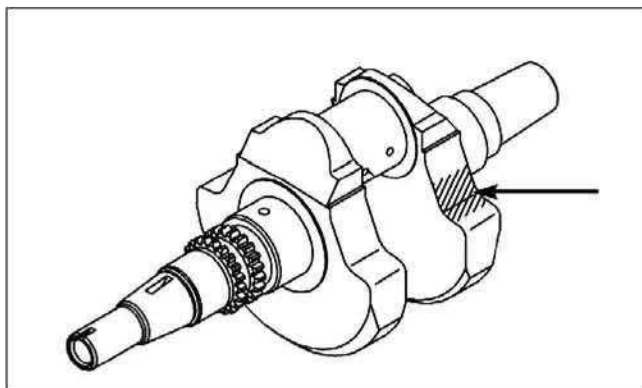

ATV2073A

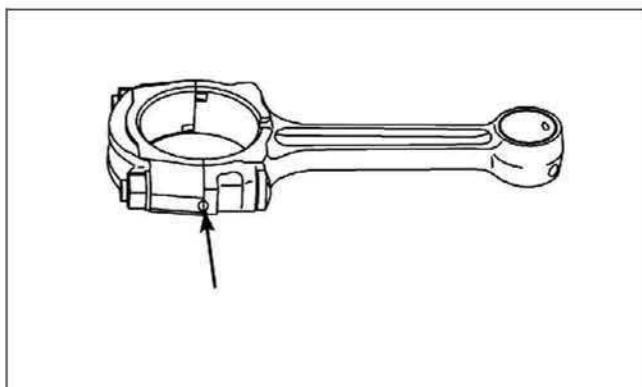

ATV2074A

7. Install the inserts into the connecting rods and caps; then use plastigauge (A) to measure connecting rod/crankshaft clearance (B). Tighten the connecting rod nuts to specifications.

■ **NOTE:** Do not move the connecting rod with plastigauge installed or the reading will be compromised.

8. Remove the connecting rods and read the clearance with the gauge provided. The clearance must be 0.028-0.052 mm (0.0011-0.0020 in.) standard with a maximum service limit of 0.09 mm (0.0035 in.).

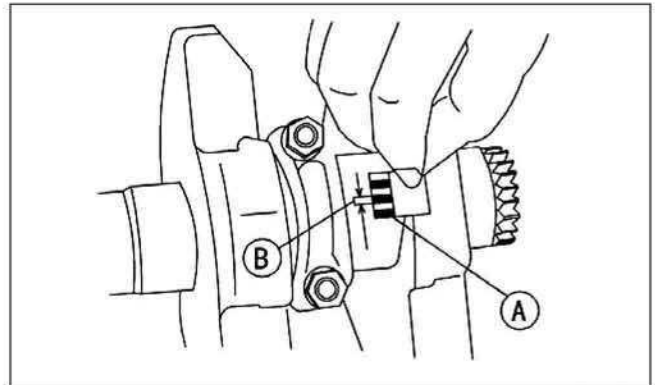

ATV2072A

9. Clean off all traces of plastigauge from the crankshaft and inserts; then assemble on the crankshaft using clean, molybdenum disulfide oil on the inserts (A). Make sure that the "OUT" marks (B) on both connecting rods are directed towards the outside of the crankshaft and the grooves (C) of the cap and connecting rod are on the same side.

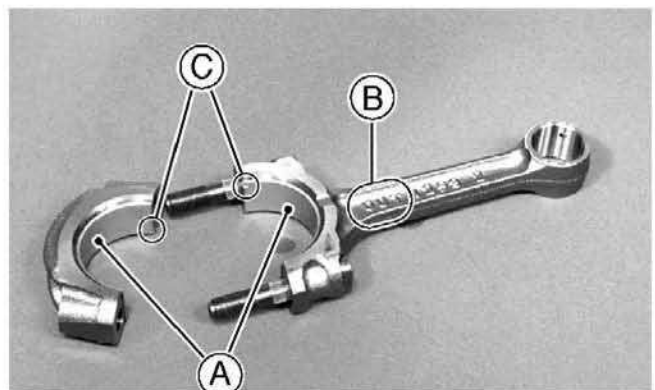

KX313

10. Install the crankshaft assembly in the right crankcase half.
11. Using a press, install the driven shaft in the crankcase until it is bottomed; then install the needle bearings (B) on the low gear (A) along with the high gear (D).